

# IES6306 Series Managed Industrial Ethernet Switch Quick Installation Guide

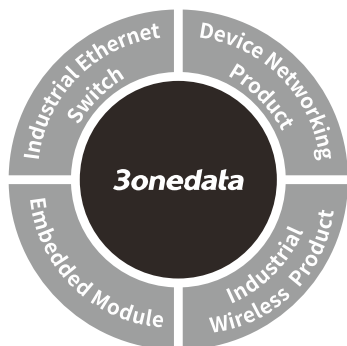

**3onedata Co., Ltd.**

Address: 3/B, Zone 1, Baiwangxin High Technology Industrial Park, Xili, Nanshan District, Shenzhen

Website: [www.3onedata.com](http://www.3onedata.com)

Tel: +86 075526702688

Fax: +86 075526703485

## 【Package Checklist】

Please check the integrity of package and accessories while first using the switch.

- |                                 |                  |
|---------------------------------|------------------|
| 1. Industrial Ethernet switch   | 2. Certification |
| 3. Quick installation guide     | 4. Warranty card |
| 5. DIN-Rail mounting attachment | 6. CD            |

If any of these items are damaged or lost, please contact our company or dealers, we will solve it ASAP.

## 【Product Overview】

This series product is Gigabit managed DIN-Rail industrial Ethernet switch. The model is:

- Model I. IES6306-4GT2HS-2P48 (4 Gigabit Copper Ports + 2 2.5G SFP + 2 12~48 Power Supplies)
- Model II. IES6306-4GP2HS-2P48-120W (4 Gigabit PoE Copper Ports + 2 2.5G SFP + 2 48VDC PoE Power Supplies)

## 【Panel Design】

➤ Top view, bottom view and rear view

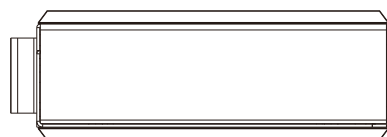
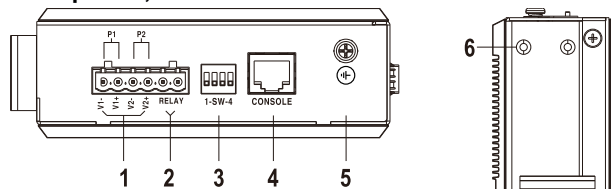

➤ Front View

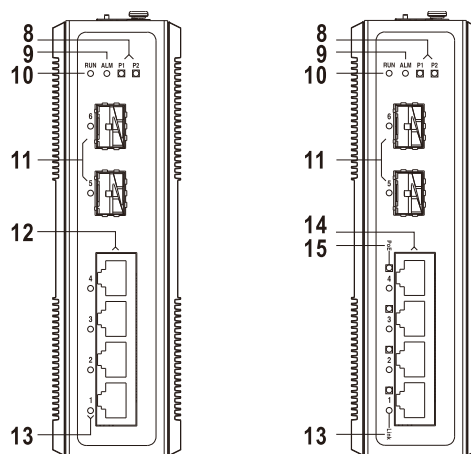

Model I

Model II

1. Power input terminal (P1, P2)
2. Relay alarm output terminal block
3. DIP switch
4. Console port
5. Grounding screw
6. Location hole for wall mounting
7. DIN-Rail mounting kit
8. Power input status indicator P1-P2

9. Relay alarm indicator ALM
10. Device running indicator RUN
11. 2.5G SFP slot (5-6)
12. Copper port (1-4)
13. Ethernet interface status indicator (1-6)
14. Gigabit PoE port (1-4)
15. PoE status indicator (1-4)

## 【Mounting Dimension】

Unit: mm

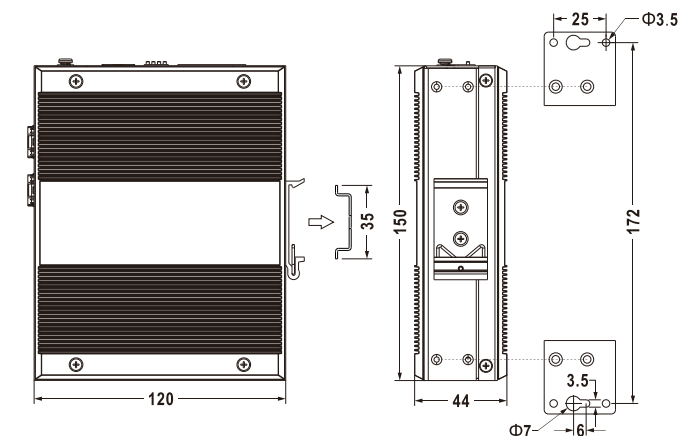

## Notice Before Mounting:

- Don't place or install the device in area near water or moist, keep the relative humidity of the device surrounding between 5%~95% without condensation.
- Before power on, first confirm the supported power supply specification to avoid over-voltage damaging the device.
- The device surface temperature is high after running; please don't directly contact to avoid scalding.

## 【DIN-Rail Mounting】

The product adopts 35mm standard DIN-Rail mounting which is suitable for most industrial scenes, mounting steps as follows:

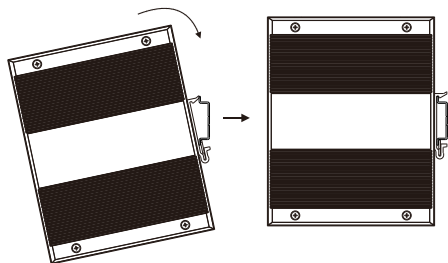

Step 1 Check if the DIN-Rail mounting kit is installed firmly.

Step 2 Insert the bottom of DIN-Rail mounting kit (one side with spring support) into DIN-Rail, and then insert the top into DIN-Rail.

Tips:

Insert a little to the bottom, lift upward and then insert to the top.

Step 3 Check and confirm the product is firmly installed on DIN-Rail, then mounting ends.

### 【Disassembling DIN-Rail】

Step 1 Power off device.

Step 2 After lifting the device upward slightly, first shift out the top of DIN-Rail mounting kit, and then shift out the bottom of DIN-Rail, disassembling ends.



### Notice before power on:

- Power ON operation: First insert the power supply terminal block into the device power supply interface, and then plug the power supply plug contact and power on.
- Power OFF operation: First, remove the power plug, and then remove the wiring section of terminal block. Please pay attention to the above operation sequence.

### 【Power Supply Connection】

#### ➤ Model I

This Model I device provides 6-pin 5.08mm pitch input terminal blocks, including 4 pins power supply terminal blocks

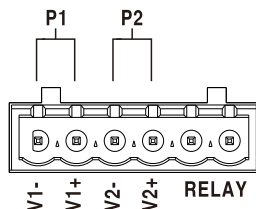

on the left side. It provides two independent DC power supply systems of P1 and P2. The power supply supports non-polarity and anti-reverse connection, which can ensure the normal operation of the device after it's reversely connected. Voltage range 12~48VDC.

#### ➤ Model II

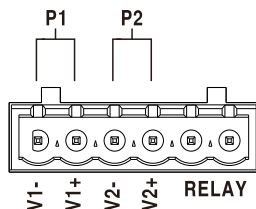

This Model II device provides 6-pin 5.08mm pitch input terminal blocks, including 4 pins power supply terminal blocks on the left side. It provides two independent DC power supply systems of P1 and P2.

The power supply supports anti-reverse connection, which can prevent device from damage after it's reversely connected, but it cannot be powered on. Voltage range is as below:

- Voltage range without using PoE function: 12~48VDC
- Rated voltage: 48VDC
- Maximum voltage range: 44VDC-55VDC

### 【Relay Connection】

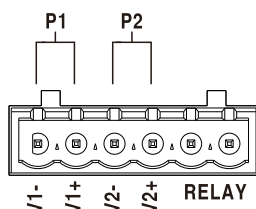

This series device provides 6-pin 5.08mm pitch input terminal blocks, and the relay occupies the right 2 pins. Relay terminals are a set of normally open contacts of the device alarm relay. They are open circuit in the state of normal non alarm, closed when any alarm information occurs. For example, they are closed when powered off, and send out alarm. The switch supports 1 relay alarm information output that can output DC power supply alarm information or network abnormality alarm. It can be connected to alarm light or alarm buzzer or other switching value collecting devices, which can timely inform operators when the alarm occurs.

### 【DIP Switch Settings】



Provide 4 pins DIP switch for function settings, where "ON" is enable valid terminal. The device needs to be powered on again to change the status of DIP switch.

DIP switches definition as follows:

DIP	Definition	Operation
1	Restore Factory Settings	Set the DIP switch to ON, the device will root automatically and restore to factory settings, then turn off the DIP switch.
2	Reserved	-
3	Reserved	-
4	Reserved	-

### 【Checking LED Indicator】

The device provides LED indicators to monitor the device working status with a comprehensive simplified troubleshooting; the detailed status of each LED is described in the table as below:

LED	Indicate	Description
P1	ON	P1 is connected and running normally
	OFF	P1 is disconnected and running abnormally
P2	ON	P2 is connected and running normally
	OFF	P2 is disconnected and running abnormally
ALM	ON	Power supply link has alarm
	OFF	Power supply link have no alarm
RUN	ON	The device is powered on or the device is abnormal.
	OFF	The device is powered off or the device is abnormal.
	Blinking	Blinking 1 time per second, the device is running well.
Link/Act (1-6)	ON	The Ethernet interface has established a valid network

		connection.
	Blinking	The Ethernet interface is in a network activity state.
	OFF	The Ethernet port has not established a valid network connection
PoE(1-4)	ON	PoE port is powering PD normally
	Blinking	PoE port is in the detection or fault state
	OFF	PoE port is not connected to PD

### 【Specification】

Panel	
2.5G SFP slot	100/1000 Base-X self-adaption or 100/1000/2.5G Base-X forced mode, SFP slot
Gigabit copper port	10/100/1000 Base-T(X) self-adapting RJ45 port, half/full duplex self-adaption or forced working mode, support MDI/MDI-X self-adaption
Gigabit PoE port	10/100/1000 Base-T(X) self-adapting RJ45 port, half/full duplex self-adaption or forced working mode, support MDI/MDI-X self-adaption; the single port supports up to 30W PoE output power, PoE power supply pin: V+, V+, V-, V- correspond to Pin 1, 2, 3, 6
Console port	CLI command management port (RS-232), RJ45
Alarm interface	6-pin 5.08mm pitch terminal blocks, alarm occupies 2 pins and 1 relay alarm information output is supported, the current load capability is 1A@30VDC or 0.3A@125VAC

Indicator	Power supply indicator, run indicator, interface indicator, alarm indicator, PoE interface indicator
Switch Property	
Backplane bandwidth	30G
Packet buffer size	4Mbit
MAC Address Table	8K
Power Supply	
Model I	12~48VDC Support dual power supply redundancy, non-polarity and anti-reverse connection
Model II	<ul style="list-style-type: none"> <li>● Voltage range without using PoE function: 12~48VDC;</li> <li>● Rated voltage: 48VDC;</li> <li>● Maximum voltage range: 44VDC-55VDC;</li> </ul> Support dual power supply redundancy, anti-reverse connection
Access terminal block	6-pin 5.08mm pitch terminal blocks, power supply occupies 4 pins
Power Consumption	
Model I	No-load: 3.74W@48VDC Full-load: 9.6W@48VDC
Model II	No-load: 4.03W@48VDC Full-load: <130W@48VDC
Working Environment	
Working temperature	-40~75°C
Storage temperature	-40~85°C
Working humidity	5%~95% (no condensation)
Protection grade	IP40 (metal shell)