

IES2312-8GT2GS2HS-2P48 Unmanaged Industrial Ethernet Switch Quick Installation Guide

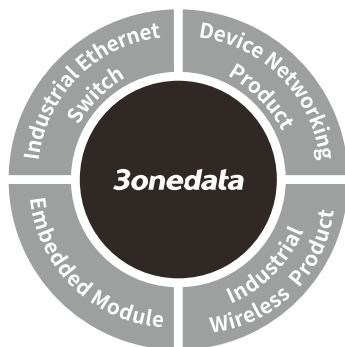

3onedata Co., Ltd.

Address: 3/B, Zone 1, Baiwangxin High Technology Industrial Park, Xili, Nanshan District, Shenzhen

Website: www.3onedata.com

Tel: +86 0755-26702688

Fax: +86 0755-26703485

【Package Checklist】

Please check the integrity of package and accessories while first using the switch.

1. Industrial Ethernet switch
2. DIN-Rail mounting attachment
3. Certification
4. Warranty card

If any of these items are damaged or lost, please contact our company or dealers, we will solve it ASAP.

【Product Overview】

This product is unmanaged DIN-Rail industrial Ethernet switch. The model is: IES2312-8GT2GS2HS-2P48 (8 Gigabit copper ports + 2 Gigabit SFP slots + 2 2.5G SFP slots, 12~48VDC redundant power supply)

【Panel Design】

➤ Top view, bottom view and rear view

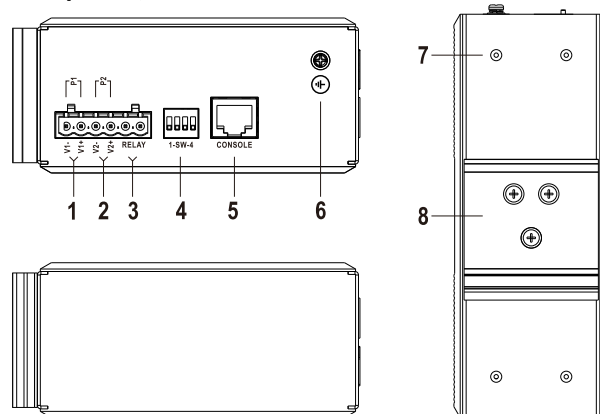

➤ Main view and right view

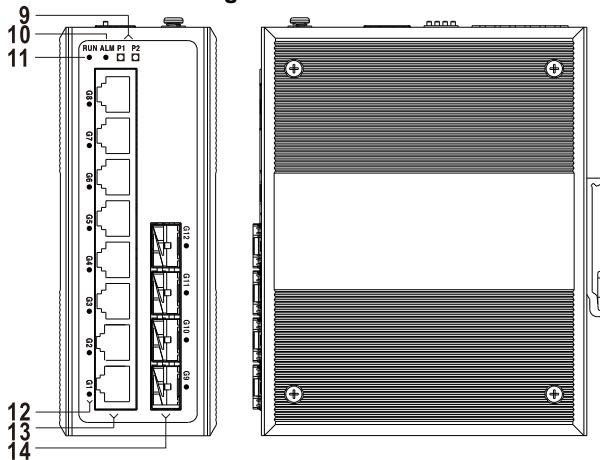

1. Terminal blocks for Power P1 input
2. Terminal blocks for Power P2 input
3. Terminal blocks for relay alarm output
4. DIP switch
5. Console port
6. Grounding screw
7. Wall-mounting location hole

8. DIN-Rail mounting kit
9. Power supply indicator (P1-P2)
10. Alarm indicator (ALM)
11. Running indicator (RUN)
12. Interface indicator (G1-G12)
13. 10/100/1000Base-T(X) copper port (G1-G8)
14. 2.5G SFP Slot (G9-G10), Gigabit SFP Slot (G11-G12)

【Mounting Dimension】

Unit: mm

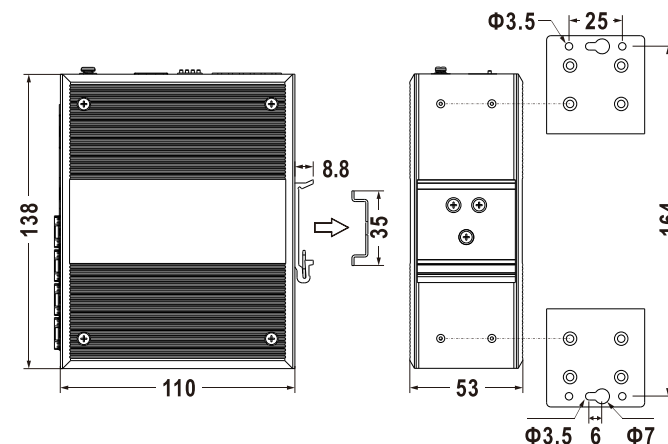

Notice Before Mounting:

- Don't place or install the device in area near water or moist, keep the relative humidity of the device surrounding between 5%~95% without condensation.
- Before power on, first confirm the supported power supply specification to avoid over-voltage damaging the device.
- The device surface temperature is high after running; please don't directly contact to avoid scalding.

【DIN-Rail Mounting】

The product adopts 35mm standard DIN-Rail mounting which is suitable for most industrial scenes, mounting steps as follows:

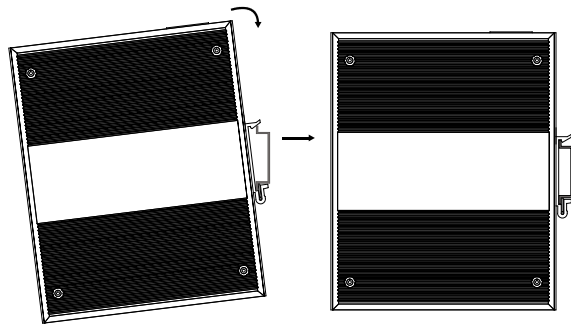

- Step 1 Check if the DIN-Rail mounting kit is installed firmly.
- Step 2 Insert the bottom of DIN-Rail mounting kit (one side with spring support) into DIN-Rail, then insert the top into DIN-Rail.
- Tips:
Insert a little to the bottom, lift upward and then insert to the top.
- Step 3 Check and confirm the product is firmly installed on DIN-Rail, then mounting ends.

【Disassembling DIN-Rail】

- Step 1 Power off device.
- Step 2 After lifting the device upward slightly, first shift out the top of DIN-Rail mounting kit, and then shift out the bottom of DIN-Rail, disassembling ends.



Notice before power on:

- Power ON operation: First insert the power supply terminal block into the device power supply interface, then plug the power supply plug contact and power on.
- Power OFF operation: First, remove the power plug, then remove the wiring section of terminal block. Please pay attention to the above operation sequence.

【Power Supply Connection】

The device provides 6-pin 5.08mm pitch power supply terminal blocks and power supply occupies the left 4 pins. It

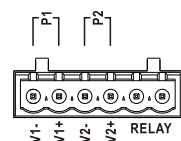

supports two independent DC power supply systems, P1 and P2. Power supply provides built-in 3A overcurrent protection, and supports non-polarity and redundant backup. Power supply range: 12~48VDC.

【Relay Connection】

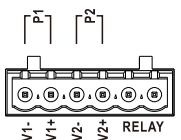

This device provides 6-pin 5.08mm pitch input terminal blocks, and the relay occupies the right 2 pins. Relay terminals are a set of normally open contacts of the device alarm relay. They are open circuit in the state of normal non alarm, closed when any alarm information occurs. For example, they are closed when powered off, and send out alarm. The switch supports 1 relay alarm information output that supports DC power supply alarm and port alarm information output. It can be connected to alarm light, alarm buzzer or other switching value collecting devices; it can timely inform operators when the alarm occurs.

【DIP Switch Settings】



The device provides 4-pin DIP switch for function setting, in which “ON” is the enabled end. The definitions of DIP switch are as follows:

DIP	Definition	Operation
1	Storm suppression	Set the DIP to “ON”
2	Jumbo frame (9600 Bytes)	Set the DIP to “ON”
3	Relay alarm	Set the DIP to “ON”
4	IEEE802.3az Energy Efficient	Set the DIP to “ON”

【Checking LED Indicator】

The device provides LED indicators to monitor its operating status, which has simplified the overall troubleshooting process. The function of each LED is described in the table below:

LED	Indicate	Description
P1/P2	ON	Power supply is running normally
	OFF	Power supply is disconnected or

LED	Indicate	Description
		running abnormally
ALM	ON	Power supply or port connection has alarm
	OFF	Power supply and port has no alarm or the alarm function is disabled.
RUN	ON	Device is not started or abnormal
	OFF	The device is powered off or the device is abnormal.
	Blinking	Blinking 1 time per second, the device is running normally.
G1-G12	ON	Ethernet port has established a valid network connection.
	Blinking	Ethernet port is in an active network status.
	OFF	Ethernet port has not established valid network connection

【Specification】

Panel	
Gigabit copper port	10/100/1000Base-T(X) self-adaption, RJ45, Automatic Flow Control, Full/Half Duplex Mode, MDI/MDI-X Autotuning
Gigabit SFP slot	100/1000Base-X self-adaption, SFP slot
2.5G SFP slot	100/1000/2.5GBase-X self-adaption, SFP slot
Console port	Reserved
Alarm interface	6-pin 5.08mm pitch terminal blocks, including 2-pin alarm terminal blocks. It supports 1 channel relay alarm information output, current load capacity is 1A@30VDC or 0.3A@125VAC
Indicator	Running Indicator, Alarm

	Indicator, Power Supply Indicator, Interface Indicator
Switch Property	
Backplane bandwidth	30G
Packet buffer size	4Mbit
MAC address table	8K
Power Supply	
Power input	12~48VDC, non-polarity, redundant backup, built-in 3A overcurrent protection
Access terminal blocks	6-pin 5.08mm pitch terminal blocks, power supply occupies 4 pins
Power Consumption	
No-load	5.76W@48VDC
Full-load	12W@48VDC
Working Environment	
Working temperature	-40~75°C
Storage temperature	-40~85°C
Working humidity	5%~95%(no condensation)
Protection grade	IP40 (metal shell)