



IEM618-4D-2C

Embedded Mounting

8-port 100M Layer 2 Managed Industrial Ethernet Switch Module with 4 Serial Ports and 2 CAN Ports

- Support 8 100M fiber/copper ports, 4 serial ports and 2 CAN ports
- Adopt SW-Ring patent technology, support single ring, coupling ring, chain ring, Dual-homing ring network function, automatic recovery time of network failure < 20ms
- Input voltage: 3.3VDC
- Support -40 ~ 85°C wide operating temperature range



Introduction

IEM618-4D-2C is 8-port 100M layer 2 managed embedded industrial Ethernet switch module with 4 serial ports and 2 CAN ports featuring high integration level, small size, rich functions, easy and convenient usage. This series have 3 types of products. It provides 4 serial ports, 2 CAN ports, and 8 100M ports which could be configured to fiber port or copper port as needed. It also adopts embedded mounting that user can custom the specification of PCB motherboard and freely choose Ethernet interface type through module pin to meet the requirements of different scenes.

Network management system supports various network protocols and industrial standards, such as STP/RSTP, 802.1Q VLAN, QoS, IGMP Static Multicast, Port Trunking, LLDP, Port Mirroring, etc. It also possesses complete management functions, including Port Configuration, Port Statistics, Access Control, Network Diagnosis, Rapid Configuration, Online Upgrading and so on. It has integrated functions of serial port server and CAN server. Each serial port and CAN port support 4 TCP or UDP session connections and multiple operating modes including TCP Server, TCP Client and UDP, etc. CLI, WEB, Telnet, SNMP and other access methods are also supported. The network management system can provide users with good experience with friendly design of network management system interface, simple and convenient operation.

Hardware adopts fanless, low power consumption, wide temperature design and has passed rigorous industrial standard tests, which can suit for the industrial scene environment with harsh requirements for EMC. It can be widely used in smart grid, railway transportation, smart city, safe city, new energy, intelligent manufacturing and other industrial fields.

Features and Benefits

- ⊙ SNMPv1/v2c is used for network management of various levels
- ⊙ Port mirroring can conduct data analysis and monitoring, which is convenient for online debugging
- ⊙ QoS supports real-time traffic classification and priority setting
- ⊙ LLDP can achieve automatic topology discovery, which is convenient for visual management
- ⊙ File management is convenient for rapid configuration and online upgrade of the device
- ⊙ Bandwidth management can reasonably distribute network bandwidth, preventing unpredictable network status
- ⊙ Port statistics can be used for the port real time traffic statistics
- ⊙ User password can conduct user hierarchical management to improve the device administrative security
- ⊙ Relay alarm is convenient for troubleshooting of construction site

- ⦿ VLAN can simplify the network planning
- ⦿ Port trunking can increase network bandwidth and the reliability of network connection to achieve optimal bandwidth utilization
- ⦿ IGMP-Snooping and static multicast can be used for filtering multicast traffic to save the network bandwidth
- ⦿ SW-Ring and STP/RSTP can achieve network redundancy, preventing network storm
- ⦿ Supports multiple serial port operating modes: TCP Server, TCP Client, UDP, TCP auto, Realcom, advanced TCP Server and advanced UDP
- ⦿ Supports multiple CAN port operating modes: TCP Server, TCP Client, UDP, TCP auto, Realcom, advanced TCP Server and advanced UDP

Dimension

Unit:mm

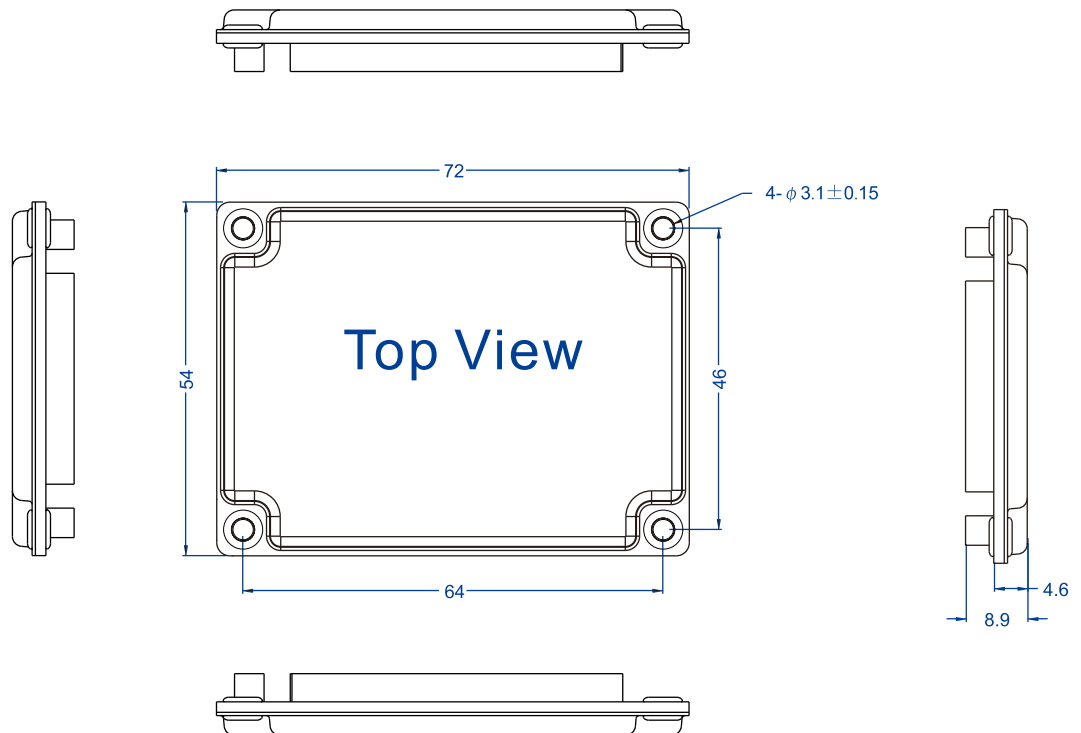

Specification

Standard & Protocol	IEEE 802.3 for 10Base-T IEEE 802.3u for 100Base-TX and 100Base-FX IEEE 802.3x for Flow Control IEEE 802.1D for Spanning Tree Protocol IEEE 802.1w for Rapid Spanning Tree Protocol IEEE 802.1Q for VLAN
---------------------	--

	IEEE 802.1p for CoS
Management	SNMP v1/v2c Centralized Management of Equipment, Port Mirroring, QoS, DHCP Client, File Management, Port Statistics
Security	Classification of User Permissions, Port Alarm, Power Supply Alarm, Threshold Alarm
Switch Function	802.1Q Vlan, Static Port Aggregation, Bandwidth Management, Flow Control
Unicast / Multicast	Static Multicast, IGMP-Snooping
Redundancy Protocol	SW-Ring, STP/RSTP
Interface	100M port: 10/100Base-T(X) or 100Base-FX, fiber/copper port Console port: TTL level serial data Alarm port: support 2 alarm information input and output
Serial Port	Interface type: 4 full signal TTL level serial port (RS-232/485/422 optional) Baud rate: 300-115200bps Data bit: 5bit, 6bit, 7bit, 8bit Check bit: None, Even, Odd, Space, Mark Stop bit: 1bit, 1.5bit, 2bit
CAN Port	Interface type: 2 TTL level CAN port Baud rate: 5-1000kbps
LED Indicator	External indicator, running indicator, port indicator
Switch Property	Transmission mode: store and forward MAC address: 2K Packet buffer size: 1Mbit Backplane bandwidth: 2G Switch time delay: <10μs
Power Requirement	3.3VDC(±5%)
Power Consumption	Power consumption: < 1.5W
Environmental Limit	Operating temperature: -40~85°C Storage temperature: -40~85°C Relative humidity: 5% ~ 95%(no condensation)



Physical Characteristic	Installation: embedded mounting (with heat-conducting fin, can be equipped with heatsink) Dimension (W x H x D): 72mm×9.5mm×54mm
Certification	CE, FCC, RoHS
Warranty	5 years



Ordering Information

Available Models	100M Port (Optional Fiber/Copper Port)	Serial port (Optional RS-232/485/422)	CAN Port	Power Supply
IEM618-4D-2C	8	4	2	3.3VDC(±5%)



Address: 3/B, Zone 1, Baiwangxin High Technology Industrial Park, Song Bai Road, Nanshan District, Shenzhen, 518108, China

TEL.: +86-755-26702668 ext 835 FAX: +86-755-26703485

E-mail: ics@3onedata.com

Website: www.3onedata.com

◀ [Please scan our QR code for more details](#)

*Product pictures and technical data in this datasheet are only for reference. Updates are subject to change without prior notice. The final interpretation right is reserved by 3onedata.