

IES6100PN-8T-2LV Managed PROFINET Industrial Ethernet Switch Quick Installation Guide

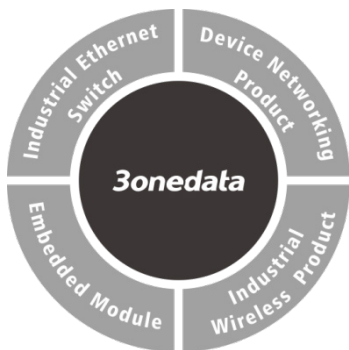

3onedata Co., Ltd.

Address: 3/B, Zone 1, Baiwangxin High Technology Industrial Park, Xili, Nanshan District, Shenzhen

Website: www.3onedata.com

Tel: +86 0755-26702688

Fax: +86 0755-26703485

【Package Checklist】

Please check the integrity of package and accessories while first using the switch.

1. Industrial Ethernet switch
2. Warranty card
3. Certificate

If any of these items are damaged or lost, please contact our company or dealers, we will solve it ASAP.

【Product Overview】

This series are layer 2 managed DIN-Rail PROFINET industrial Ethernet switches. The model is IES6100PN-8T-2LV (8 100M copper ports, 12~48VDC redundant power supply input).

【Panel Design】

➤ Top view, bottom view and rear view

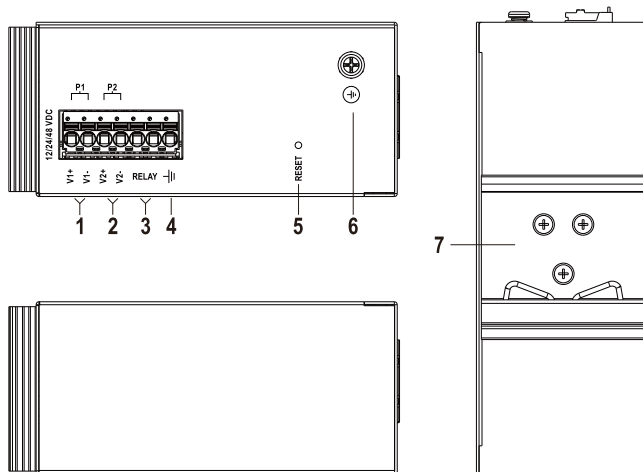

➤ Main view and right view

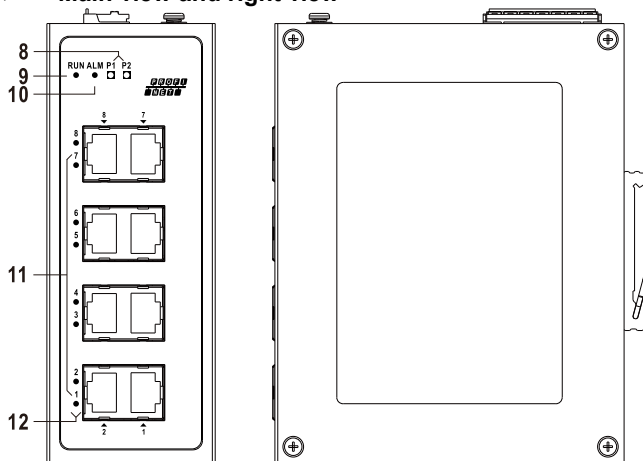

1. Terminal blocks for Power P1 input (P1)
2. Terminal blocks for Power P2 input (P2)
3. Terminal blocks for relay output (RELAY)
4. Protective shell grounding
5. RESET button
6. Grounding screw (M4)
7. DIN-Rail mounting kit
8. Power supply indicator (P1-P2)
9. Running indicator (RUN)
10. Alarm indicator (ALM)

11. 10/100Base-T(X) 100M copper port (1-8)
12. Interface indicator (1-8)

【Mounting Dimension】

Unit: mm

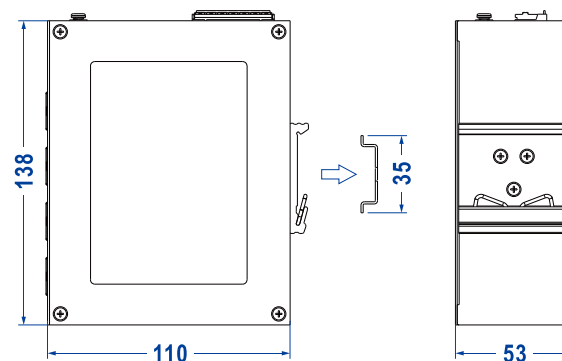

Notice Before Mounting:

- Don't place or install the device in area near water or moist, keep the relative humidity of the device surrounding between 5%~95% without condensation.
- Before power on, first confirm the supported power supply specification to avoid over-voltage damaging the device.
- The device surface temperature is high after running; please don't directly contact to avoid scalding.

【DIN-Rail Mounting】

The product adopts 35mm standard DIN-Rail mounting which is suitable for most industrial scenes, mounting steps as follows:

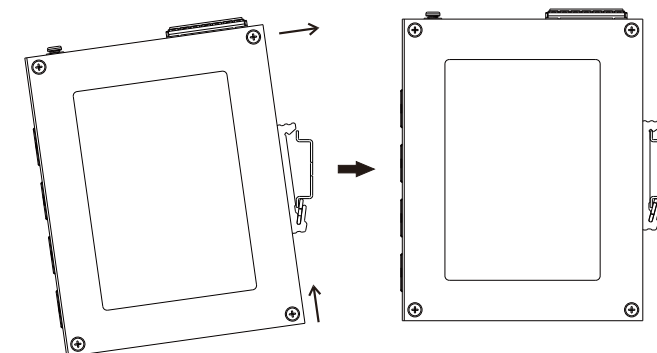

- Step 1 Check if the DIN-Rail mounting kit is installed firmly.
- Step 2 Insert the bottom of DIN-Rail mounting kit (one side with spring support) into DIN-Rail, and then insert the top into DIN-Rail.
- Tips:
Insert a little to the bottom, lift upward and then insert to the top.
- Step 3 Check and confirm the product is firmly installed on DIN-Rail, then mounting ends.

【Disassembling DIN-Rail】

- Step 1 Power off the device.
- Step 2 After pressing the device downward slightly, first shift out the top of DIN-Rail mounting kit, and then shift out the bottom of DIN-Rail, disassembling ends.



Notice before power on:

- Power ON operation: First insert the power supply terminal block into the device power supply interface, then plug the power supply plug contact and power on.
- Power OFF operation: First, remove the power plug, then remove the wiring section of terminal block. Please pay attention to the above operation sequence.

【Power Supply Connection】

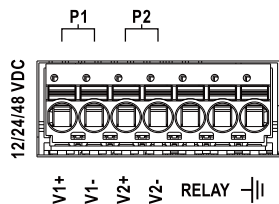

Provide 7-pin 5mm pitch terminal blocks, the power supply occupies the left 4 pins and support P1 and P2 DC redundant power input. The power input supports 1 single power supply input or 2 power supply inputs at the same time; When two power supply input at the same time, it supports redundant backup of power supply. If one power supply fails, the device can still work normally without interruption. The definitions of power pin are shown in the figure above, and the power input range is 12/24/48VDC (12~48VDC).



Notes:

The terminal blocks are pluggable and with spring. When wiring, use a slotted screwdriver to press the spring, connect the cable to the corresponding hole, and then loosen the spring part. When disassembling, the spring should also be pressed.

【Relay Connection】

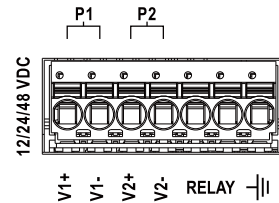

Provide 7-pin 5mm pitch terminal block (2 pins for relay), support 1 relay alarm output. In power off situation, relay (—|) is a group of normally closed contacts. After powered on, the relay is open circuit in normal non-alarm state by default, closed when any alarm information occurs. The relay supports power supply alarm, network abnormality alarm or other configuration event alarm. It can be connected to alarm light or alarm buzzer or other switching value collecting devices, which can timely inform operators when the alarm occurs.

【Reset Button Setting】

RESET ○ Provide 1 RESET button that can be used to reboot the device and restore factory defaults. Press the RESET button for 1s and release it, and the device will restart automatically; Press and hold the RESET button for 5s and release it, and the device will automatically restore the factory defaults.

【Checking LED Indicator】

Provide LED indicators to monitor its operating status, which has simplified the overall troubleshooting process. The function of each LED is described in the table below:

LED	Indicate	Description
RUN	ON	When the device works normally , the indicator is always on: <ul style="list-style-type: none"> • Orange: the PROFINET AR status is online • Green: the PROFINET AR status is

LED	Indicate	Description
		offline
	Blinking	When the current device is indicated in PROFINET configuration software, the green/orange indicator flashes at a fixed frequency
	OFF	Device is not started or device is abnormal
ALM	ON	Power, port or other configuration event has alarms
	OFF	Power, port and other configuration event has no alarm.
P1-P2	ON	Power supply is running normally
	OFF	Power supply is disconnected or running abnormally
1-8	ON	Ethernet port has established a valid network connection
	Blinking	Ethernet port is in an active network status
	OFF	Ethernet port has not established a valid network connection.

【Logging in to WEB Interface】

Support WEB management and configuration. Computer can access the device via Ethernet interface. The way of logging in to device's configuration interface via browser is shown as below:

- Step 1 Configure the IP addresses of computer and the device to the same network segment, and the network between them can be mutually accessed.
- Step 2 Enter device's IP address in the address bar of the computer browser.
- Step 3 Enter device's username and password in the login window as shown below.

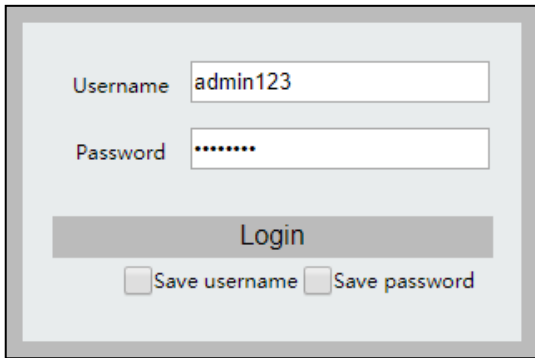

Step 4 Click "Login" button to login to the WEB interface of the device.



Note:

- The device has no IP address by default, so you can search and configure the IP address of the device through PROFINET configuration softwares such as STEP 7 and TIA Portal.
- The default user name and password is "admin123".
- If the user name or password is lost, user can restore it to factory settings via RESET button or management software; all modified configurations will be cleared after restoring to factory settings, so please backup configuration file in advance.
- Please refer to user manual for specific configuration method of logging in to WEB interface and other configurations about network management function.

【Specification】

Panel	
100M copper port	10/100Base-T(X) Self-Adaption or Forced Mode, RJ45, Automatic Flow Control, Full/Half Duplex Mode, MDI/ MDI-X Autotunning

Relay interface	Support 1 relay alarm information output, adopt 7-pin 5mm pitch terminal blocks (2-pin relay), the current carrying capacity is 1A@30VDC or 0.3A@125VAC
Indicator	Running Indicator, Alarm Indicator, Power Supply Indicator, Interface Indicator
Switch Property	
Backplane bandwidth	1.6G
Packet buffer size	2Mbit
MAC address table	8K
Power Supply	
Input power supply	12/24/48VDC (12~48VDC), dual power supply redundancy
Access terminal block	7-pin 5mm pitch terminal blocks (power supply occupies the left 4 pins)
Power Consumption	
No-load	2.2W@24VDC
Full-load	5.0W@24VDC
Working Environment	
Working temperature	-40~75°C
Storage temperature	-40~85°C
Working humidity	5%~95% (no condensation)
Protection grade	IP40 (metal shell)

【Disposal of Waste Electrical and Electronic Equipment (WEEE 2012/19/EU)】



(Applicable in the EU-member states)

The crossed-out wheeled bin symbol on the equipment or its packaging indicates that the product, at the end of its service life, shall not be mixed with

unsorted municipal waste but should be collected separately, in accordance with local laws and regulations.

A proper separate collection of end-of-life equipment for the subsequent recycling, treatment and environmentally compatible disposal, will help prevent potential damage to the environment and human health, facilitating the reuse, recycling and/or recovery of its component materials.

Private users should contact their vendor or municipal waste management service and ask for disposal information.

Professional users should contact their suppliers and check the terms of their selling agreement.

This product must not be disposed of with other commercial waste.

Users' cooperation in the correct disposal of this product will contribute to saving valuable resources and protecting the environment.