

IEM6300-12G

Embedded Mounting

12-Port Gigabit Layer 2 Managed Industrial Ethernet Switch Module

- Support 8 10/100/1000Base-T(X) Gigabit copper ports and 4 1000Base-X Gigabit fiber ports
- Adopt Ring patented technology, support single ring, coupling ring, chain, Dual-homing, automatic recovery time of network failure < 20ms
- Support multiple network protocols and industry standards, such as IPv6, STP/RSTP/MSTP, VLAN, QoS, LACP, DHCP, IGMP Snooping, LLDP, ACL, SNMP and MEP.
- Input voltage: 3.3VDC
- Support -40~75°C wide operating temperature range

Introduction

IEM6300-12G is a 12-port layer 2 managed embedded industrial Gigabit Ethernet switch module, which has the characteristics of high integration, small size, rich functions, simple and convenient operation. The product provides 8 Gigabit copper ports, 4 Gigabit fiber ports; Using embedded installation mode, users can customize the PCB floor specifications, through the module pins can choose any Ethernet interface type, to meet the needs of different application sites.

The network management system supports a variety of network protocols and industry standards, such as IPv6, Ring, STP/RSTP/MSTP, DHCP Server/Snooping/Relay, VLAN, QoS, IGMP Snooping, LLDP, Port Trunking and Port Mirroring. It possesses complete management functions and supports Port Configuration, NAS, ACL, Network Diagnosis, Online Upgrade, etc. CLI, WEB, TELNET, SSH, SNMP and other access methods can be supported. Network management system could bring you great user experience through its friendly interface design and easy and convenient operation.

Hardware adopts low power consumption, wide temperature design and has passed rigorous industrial standard tests, which can suit for the industrial scene environment with harsh requirements for EMC. It can be widely used in smart grid, rail transit, smart city, safety city, new energy, intelligent manufacturing and other industrial fields.

Features and Benefits

- ⊙ IPv6 supports end-to-end security and provides enormous address space, facilitating the hierarchical network design
- ⊙ SNMPv1/v2c/v3 is used for network management of various levels
- ⊙ RMON can be used for efficient and flexible network monitoring
- ⊙ QoS supports real-time traffic classification and priority setting
- ⊙ LLDP can achieve automatic topology discovery, which is convenient for visual management
- ⊙ DHCP server and DHCP client could be used for allocating IP address of different strategies
- ⊙ DHCP Snooping can ensure DHCP client gets IP address from legal DHCP server
- ⊙ DHCP relay function can realize IP address, gateway, DNS configuration cross network segment
- ⊙ File management is convenient for the device rapid configuration and online upgrading
- ⊙ User privilege classification configuration can set user privilege level
- ⊙ SSH configuration and HTTPS configuration can improve device's management security and guarantee data access security
- ⊙ Support NAS network access service and provide security assurance for multiple services
- ⊙ MEP function can determine the scope and boundary of maintenance domain

- Ring and STP/RSTP/MSTP can achieve network redundancy, preventing network storm
- Storm suppression can restrain broadcast, unknown multicast and unicast
- VLAN is used for simplifying network planning
- Port Trunking and LACP can increase network bandwidth and enhance the reliability of network connection to achieve optimum bandwidth utilization
- IGMP Snooping can be used for filtering multicast traffic to save the network bandwidth
- Support DDM (digital diagnostic monitoring) function, which can monitor the optical power, temperature and other real-time parameters of SFP fiber module with DDM function, facilitating the link default diagnosis of optical fiber
- Network diagnosis and troubleshooting could be conducted via Ping, Ping6 and cable detection
- Port mirroring can conduct data analysis and monitoring, which is convenient for online debugging

Dimension

Unit: mm

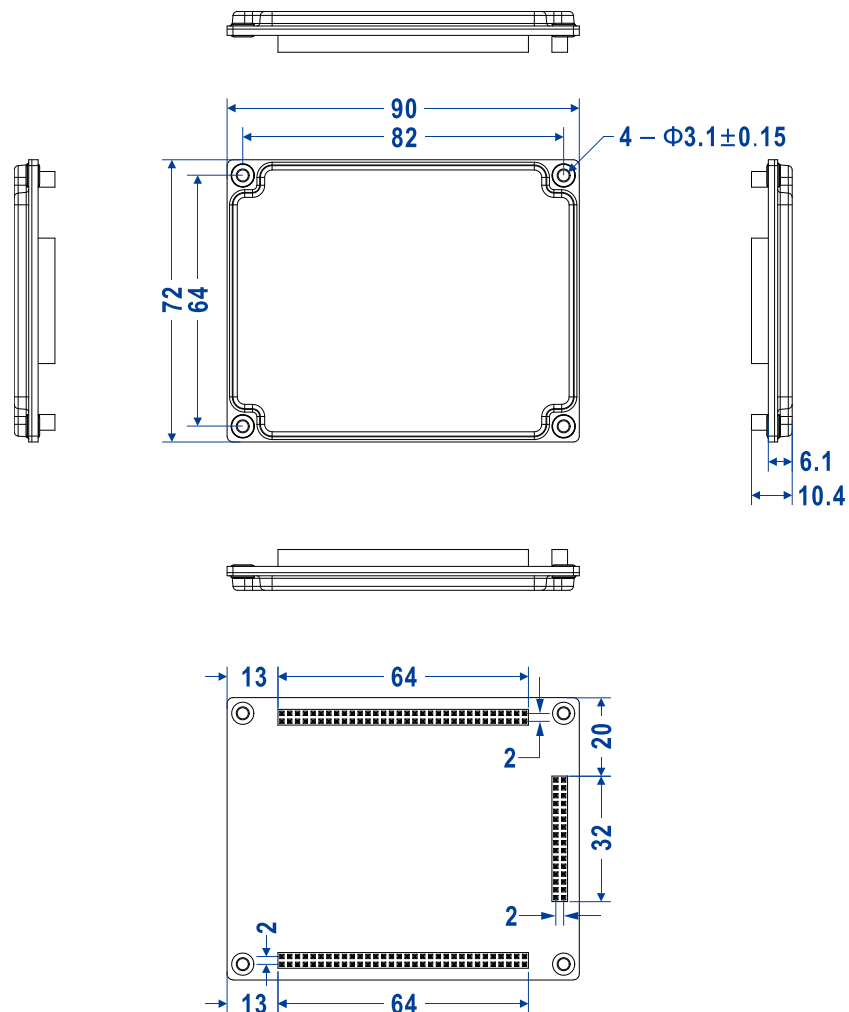

Specification

<p>Standard & Protocol</p>	<p>IEEE 802.3 for 10Base-T IEEE 802.3u for 100Base-TX and 100Base-FX IEEE 802.3z for 1000Base-X IEEE 802.3ab for 1000Base-T IEEE 802.3x for Flow Control IEEE 802.1D for Spanning Tree Protocol IEEE 802.1w for Rapid Spanning Tree Protocol IEEE 802.1s for Multiple Spanning Tree Protocol IEEE 802.1Q for VLAN IEEE 802.1p for CoS IEEE 802.1X for 802.1X Authentication IEEE 802.1AB for LLDP IEEE 802.3ad for LACP</p>
<p>Management</p>	<p>SNMP v1/v2c/v3 Centralized Management of Equipment, RMON, QoS, DHCP Server, DHCP Relay, Static MAC Address, LLDP, LLDP-MED, User Password, Login Method, File Management, Log Management, Port Statistics, MEP</p>
<p>Security</p>	<p>User Privilege Classification, Authentication Method Configuration, SSH Configuration, HTTPS Configuration, Access Control, Port Limit Control, Port Security, NAS, ACL, Ethernet Services, RADIUS Server Authentication, TACACS + Server Authentication, Storm Suppression, DHCP Snooping, Relay Alarm, Loop Protection, Temperature Protection</p>
<p>Switch Function</p>	<p>802.1Q VLAN, Static Aggregation, LACP</p>
<p>Unicast / Multicast</p>	<p>IGMP Snooping, Unicast MAC</p>
<p>Redundancy Technology</p>	<p>Ring, STP/RSTP/MSTP</p>
<p>Troubleshooting</p>	<p>Ping, Ping6, Cable Detection, Port Mirroring, DDMI</p>
<p>Time Management</p>	<p>NTP server, NTP client, Time zone configuration</p>
<p>Interface</p>	<p>Gigabit copper port: 8 10/100/1000Base-T(X) Gigabit fiber port: 4 1000Base-X, SGMII Console port: TTL level serial data Alarm interface: support 2 alarm information inputs and 1 alarm information output</p>

Switch Property	Transmission mode: store and forward 100M forwarding speed: 148810pps Gigabit forwarding speed: 1488100pps MAC address: 8K Buffer: 4Mbit Backplane bandwidth: 24G Switch time delay: <10 μ s
Power Supply	3.3VDC
Power Consumption	No-load: 2.7W (including DEMO board@12VDC) Full-load: 8.4W (including DEMO board@12VDC)
Working Environment	Operating temperature: -40~75 $^{\circ}$ C Storage temperature:-40~85 $^{\circ}$ C Relative humidity: 5%~95% (no condensation)
Physical Characteristic	Installation: embedded mounting Dimension (W x H x D): 90mm \times 10.4mm \times 72mm
Warranty	5 years

Ordering Information

Available Models	Gigabit Copper Port	Gigabit Fiber Port	Power Supply
IEM6300-12G	8	4	3.3VDC



Address: 3/B, Zone 1, Baiwangxin High Technology Industrial Park, Song Bai Road, Nanshan District, Shenzhen, 518108, China

TEL.: +86-755-26702668 ext 835 FAX: +86-755-26703485

E-mail: ics@3onedata.com

Website: www.3onedata.com

◀ Please scan our QR code for more details

*Product pictures and technical data in this datasheet are only for reference. Updates are subject to change without prior notice. The final interpretation right is reserved by 3onedata.