



TNS5500D Series (8-Port)

Wall/Rail Mounting

8-Port 100M Layer 2 Managed Industrial Ethernet Switch for Rail Transit

- Support 8 100M M12
- Adopt SW-Ring patented technology, support single ring, coupling ring, chain, Dual-homing function
- Support 110VDC (66~154VDC) or 24VDC(9~36VDC) power supply input
- Support -40~ 75°C wide temperature operation



Industrial Grade



EN 50155



EN 50121



Introduction

TNS5500D series is 8-port 100M layer 2 managed industrial Ethernet switch designed for rail transit. It conforms to the EN50155 and EN50121 industry standard. Ethernet interfaces, power interface and SERVICE port use firm and reliable M12 connectors which can adapt to usage scenario with severe vibration and shock. This product provides 8 100M M12 interfaces, and it adopts wall/rail mounting which can meet the requirements of different scenes.

Network management system supports various network protocols and industrial standards, such as STP/RSTP, 802.1Q VLAN, QoS function, IGMP Snooping, LLDP, Port Trunking, Port Mirroring. It also possesses complete management functions, including Port Setting, Bandwidth Management, Port Statistics, Access Control, Rapid Configuration, Online Upgrading and so on, and supports CLI, WEB, Telnet, SNMP and other access methods. Network management system could bring you great user experience through its friendly interface design and easy and convenient operation.

When port has link failure, ALARM indicator will be bright and send out alarm, meanwhile, alarm device connected to the relay will send out alarm for rapid scene troubleshooting. Hardware adopts fanless, low power consumption, wide temperature and voltage design and has passed rigorous industrial standard tests, which can suit for the industrial scene environment with harsh requirements for EMC. It is designed for rail transit industry and can be widely used in systems such as car PIS, CCTV, and train control.

Features and Benefits

- ⊙ SNMPv1/v2c is used for network management of various levels
- ⊙ Port mirroring can conduct data analysis and monitoring, which is convenient for online debugging
- ⊙ QoS supports real-time traffic classification and priority setting
- ⊙ LLDP can achieve automatic topology discovery, which is convenient for visual management
- ⊙ File management is convenient for rapid configuration and online upgrading of the device
- ⊙ Port statistics can be used for the port real time traffic statistics
- ⊙ User password can conduct user hierarchical management to improve the device management security
- ⊙ Relay alarm is convenient for troubleshooting of construction site
- ⊙ VLAN can be set to simplify network planning
- ⊙ Port Trunking can increase network bandwidth and enhance the reliability of network connection to achieve optimum bandwidth utilization
- ⊙ Bandwidth management can reasonably distribute network bandwidth, preventing unpredictable network status

- IGMP Snooping and static multicast can be used to filter multicast data to save network bandwidth
- SW-Ring and STP/RSTP can achieve network redundancy, preventing network storm
- Loop protection could efficiently eliminate the influence caused by port loopback by detecting the existence of port loopback

Dimension

Unit: mm

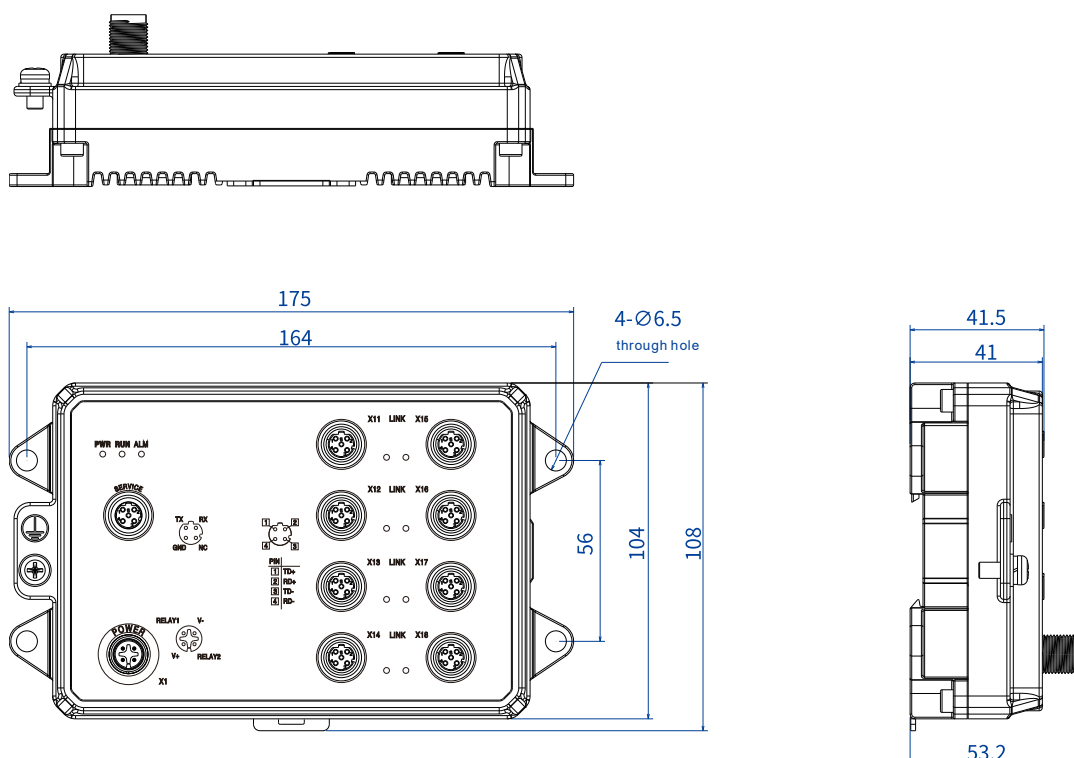

Specification

<p>Standard & Protocol</p>	<p>IEEE 802.3 for 10Base-T IEEE 802.3u for 100Base-TX IEEE 802.3x for Flow Control IEEE 802.1D for Spanning Tree Protocol IEEE 802.1w for Rapid Spanning Tree Protocol IEEE 802.1Q for VLAN IEEE 802.1p for CoS IEEE 802.1AB for LLDP</p>
---------------------------------------	----------------------------------------------------------------------------------------------------------------------------------------------------------------------------------------------------------------------------------------------------------------------------------------------------------------------------------------------------------------------------------------------

Management

SNMP v1/v2c Centralized Management of Equipment, Port

	Mirroring, QoS, LLDP, File Management, Port Statistics, and Log Information
Security	Classification of User Permissions, Port Alarm, Threshold Alarm, Loop Protection
Switch Function	802.1Q VLAN, Port Aggregation, Bandwidth Management, Flow Control
Unicast / Multicast	Static Multicast, IGMP-Snooping
Redundancy Technology	SW-Ring, STP/RSTP
Time Management	Sntp
Interface	<p>Power supply interface: M12 A-Coded 4-Pin (male) connector, the power occupies 2 pins, V- and V+</p> <p>Relay alarm interface (reserved): M12 (Male), 4-Pin A-Coded, relay occupies two pins, RELAY1 and RELAY2</p> <p>100M Ethernet port: 10/100Base-T(X), M12(Female), 4-Pin D-Code, Automatic Flow Control, Full/half Duplex Mode, MDI/MDI-X Autotuning</p> <p>Service port: CLI command line management port (RS-232), M12(Female), 4-Pin D-Code</p>
Indicator	Running Indicator, Port Indicator, Power Supply Indicator, Alarm Indicator
Switch Property	<p>Transmission mode: store and forward</p> <p>MAC address: 8K</p> <p>Buffer: 1Mbit</p> <p>Backplane bandwidth: 7.6G</p> <p>Switch time delay: <10μs</p>
Power Supply	110VDC (66~154VDC) or 24VDC (9~36VDC), M12 (Male), 4-Pin A-Coded
Power Consumption	<p>Full-load: 3.8W@24VDC</p> <p>No-load: 2.1W@24VDC</p>

Working Environment	Operating temperature: -40~75°C Storage temperature:-40~85°C Relative humidity: 5%~95% (no condensation)
Mechanical Structure	Housing: IP67 protection, metal Installation: wall/rail mounting Dimension (W x H x D): 175mm×104mm×53.2mm Weight: 0.642kg
Industrial Standard	IEC 61000-4-2 (ESD, electrostatic discharge), Level 3 <ul style="list-style-type: none">● Air discharge:± 8kV● Contact discharge: ±6kV IEC 61000-4-4 (EFT, electrical fast transient pulses), Level 3 <ul style="list-style-type: none">● Power supply: ±2kV● Ethernet port: ±1kV● Relay: ±2kV IEC 61000-4-5 (Surge), Level 3 <ul style="list-style-type: none">● Power supply: common mode±2kV, differential mode±1kV● Ethernet interface: ±2kV● Relay: common mode ±2kV, differential mode±1kV Shock: IEC 61373 Free fall: IEC 60068-2-32 Vibration: IEC 61373
Authentication	CE, FCC, RoHS, REACH, EN50155, EN50121-3-2, EN50121-4, IEC61373, EN45545, Q/CR 699-2019, Q/CRRC J26-2018
Warranty	5 years

Ordering Information

Model	100M M12	Power Supply
TNS5500D-8T-P110	8	110VDC(66~154VDC)
TNS5500D-8T-P24	8	24VDC(9~36VDC)



Address: 3/B, Zone 1, Baiwangxin High Technology Industrial Park, Song Bai Road, Nanshan District, Shenzhen, 518108, China

TEL.: +86-755-26702668 ext 835 FAX: +86-755-26703485

E-mail: ics@3onedata.com

Website: www.3onedata.com

◀ [Please scan our QR code for more details](#)

*Product pictures and technical data in this datasheet are only for reference. Updates are subject to change without prior notice. The final interpretation right is reserved by 3onedata.